

PhiBer Big Bale Accumulator



Models: 3104, 3104x, 4104 & 4104x



www.phiber.ca

OPERATOR'S MANUAL

Limitation of Liability

PhiBer Manufacturing Inc. shall not be liable for special incidental or consequential damages arising out of the use of, out of the misuse of, or inability to use any product sold by PhiBer Manufacturing Inc. Including without limitation damages or loss of other property or equipment, personal injury, loss of life, loss of profits or revenue, or claims of purchaser for any such damage or loss.

Warranty

PhiBer Manufacturing Inc. warrants its products to be free from defect in factory workmanship and material under normal use and service, when set-up and operated according to factory instructions. Warranty should be handled through PhiBer or an authorized selling dealer. Warranty is subject to the following conditions:

Warranty Claims: Must be completed within 30 days of replacement of part or parts. Claim must include serial number of accumulator, date of delivery and all other necessary particulars and explanation of problem.

Warranty Parts: Must be kept for PhiBer's inspection unless otherwise specified.

Warranty Labour: PhiBer must authorize any labour subject to warranty. PhiBer Manufacturing Inc. reserves the right to set the labor rate and time required to complete a warranty repair.

Warranty Limitations: Warranty will not be granted on any accumulator that has been misused, altered, or modified in any way. Diagnostic and service calls are not covered by warranty. Warranty covers only the cost of repair and parts; it does not include shop supplies, mileage and freight costs.

Government Legislation: Warranty terms and conditions are subject to provincial or state legislation and laws.

Warranty on cylinders, hydraulic components, electronic components, and other trade accessories are limited to the warranties made by the respective manufacturers and not by PhiBer Manufacturing Inc.

The following table shows the available warranty:

Item	Time from Purchase
Frame and other structural components	One (1) Year
Electronic components	One (1) Year
Hydraulic components	One (1) Year
Hydraulic cylinders	One (1) Year

TABLE OF CONTENTS

INTRODUCTION	3
DESCRIPTION OF THE MACHINE	4
ILLUSTRATION OF THE MACHINE	5
BALE ACCUMULATOR ASSEMBLY	5
MONITOR AND CONTROLS	6
SERIAL NUMBER LOCATION	6
SAFETY	7
SAFETY ALERT SYMBOLS	7
SIGNAL WORDS	7
OPERATOR RESPONSIBILITY	8
GENERAL SAFETY PRACTICES	9
MAINTENANCE SAFETY	10
HYDRAULIC SAFETY	11
INSTALLATION SAFETY	11
TRANSPORT SAFETY	12
SAFETY SIGNS	13
SAFETY SIGN LOCATION	13
SAFETY SIGN EXPLANATION	13
SAFETY SIGN MAINTENANCE	14

TABLE OF CONTENTS

SPECIFICATIONS	15
BALE ACCUMULATOR	15
TRACTOR REQUIREMENTS	15
HARDWARE TORQUE	16
OPERATION	17
ACCUMULATOR HYDRAULICS	17
COMPONENT CYCLE TIMES	18
CYCLE INITIATION	18
CYCLE MODE SELECTION	19
FIELD OPERATION	20
BALE TRIGGER ADJUSTMENT	21
TRANSPORTING	22
STORAGE	22
MAINTENANCE	23
TROUBLE-SHOOTING	31
INSTALLATION	33
HITCH KIT MOUNTING GUIDELINES	33
INDEX	35

INTRODUCTION

Congratulations on your purchase of the PhiBer® Large Square Bale Accumulator. The PhiBer® Bale Accumulator offers the agricultural industry a machine for uniformly arranging bales into a desired package that can be handled more efficiently.

All persons authorized to operate this equipment should read and understand the contents of this Operator's Manual, especially the Safety section. The owner or operator should seek assistance from the dealer, distributor or PhiBer® for any information not fully understood regarding the safe operation, adjustment, maintenance or repair of this equipment.

Keep this Operator's Manual in a clean, dry place that is easily accessible for reference when more detailed information is required to perform tasks related to the operation, adjustment, maintenance or repair of this equipment. It is further recommended that the contents of this Operator's Manual be reviewed at least annually by persons operating, adjusting, maintaining or repairing this PhiBer® bale accumulator and any time a new person is assigned to any of the above mentioned tasks.

Any information in this Operator's Manual that is not fully understood should be clarified by contacting the dealer, distributor or manufacturer.

The contents of this Operator's Manual are accurate up to the time of printing.

PhiBer® reserves the right to make design changes without prior notice to the end user.

INTRODUCTION

DESCRIPTION OF THE MACHINE

The operator, from the seat in the tractor cab, can choose from three different automatic discharge patterns or manually eject the bales at any time. This is all done from the operator's seat in the tractor cab. Select the desired bale packaging mode with the PhiBer[®] Bale Accumulator that will complement the preferred method of bale handling in the field.

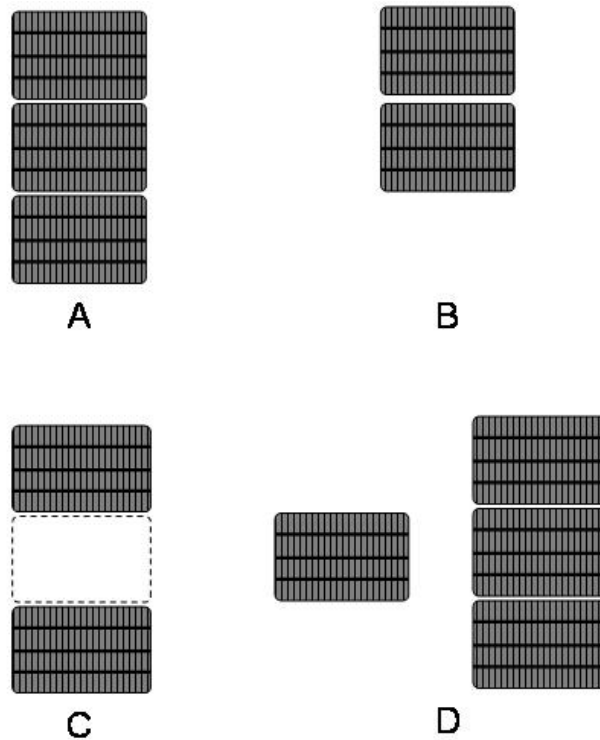

FIG. 1

BALE PACKAGING MODES

FIG. 1

- A. Three (3) Bales (default)
- B. Two (2) Bales (side-by-side)
- C. Two (2) Bales (with gap)
- D. One (1) + Three (3) Bales (delayed eject)

INTRODUCTION

ILLUSTRATION OF THE MACHINE

IMPORTANT! All references to “LEFT” or “RIGHT”, as used throughout this Operator’s Manual, are determined by facing the direction of machine forward travel when in use.

BALE ACCUMULATOR ASSEMBLY

RIGHT SIDE VIEW (FIG. 2)

- 1. Push-Off Truck
- 2. Push-Off Roller
- 3. Master Cylinder
- 4. Push-Off Limit Switch

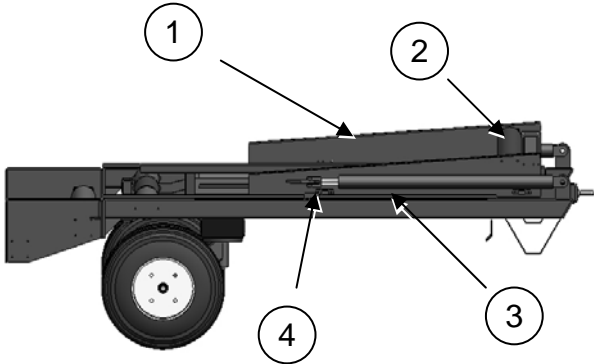

FIG. 2

LEFT CORNER VIEW (FIG. 3)

- 1. Accumulator Deck
- 2. Side-Shift Truck
- 3. Bale Trigger Button
- 4. Slave Cylinder
- 5. Track

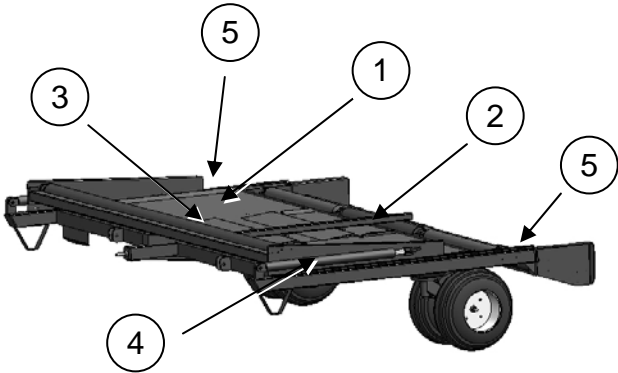

FIG. 3

INTRODUCTION

MONITOR AND CONTROLS

MONITOR/CONTROL PANEL (FIG. 4)

1. Monitor Panel
2. Power Switch
3. Eject Button
4. Indicator Lights
5. Fuse Holder

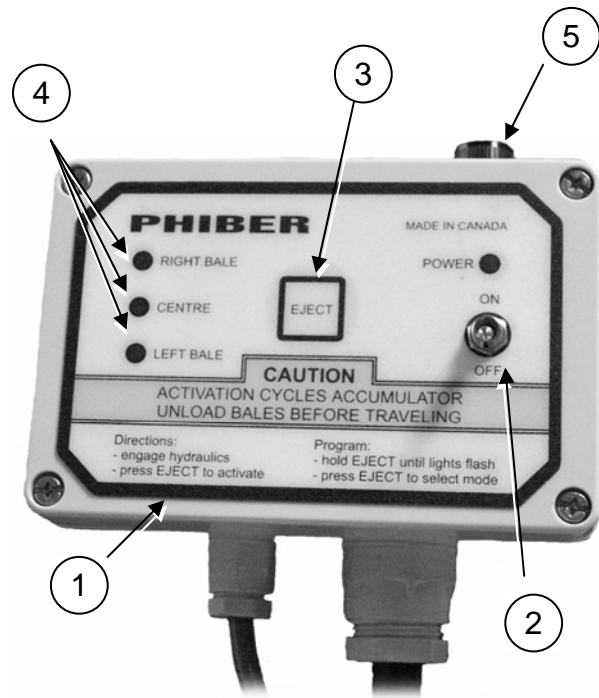

FIG. 4

SERIAL NUMBER LOCATION

The Serial Number plate, FIG. 5, is located on the inside surface of the right hand main frame member.

Record the machine Model and Serial Number in the spaces provided below. Use these numbers when contacting the dealer for repair parts or service assistance.

Model Number: _____

Serial Number: _____

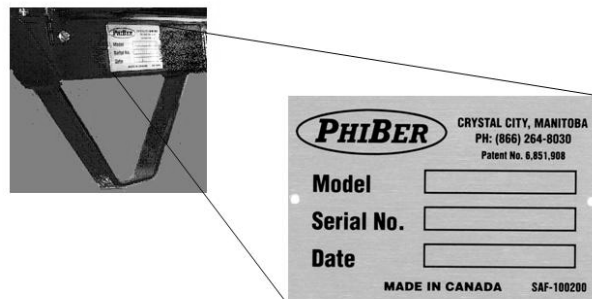

FIG. 5

SAFETY ALERT SYMBOLS

Safety Alert Symbols are intended to draw attention of the machine operator to important safety information both published in the Operator's Manual and applied to the machine. Whenever a Safety Alert Symbol is seen, it means that associated information is provided for recognizing, appropriately responding to and avoiding potentially hazardous situations.

An equilateral triangle surrounding an exclamation point or a double line equilateral triangle surrounding symbols or graphics indicates a potentially hazardous situation. Information included on a safety sign or printed in the Operator's Manual describes the hazardous situation and indicates appropriate response and/or avoidance procedures.

Remember:

**ACCIDENTS DISABLE AND KILL
ACCIDENTS ARE COSTLY
ACCIDENTS CAN BE AVOIDED**



w/ exclamation point



double line triangle

These Safety Alert Symbols Mean:

ATTENTION!

BE ALERT!

YOUR SAFETY IS INVOLVED!

SIGNAL WORDS

DANGER

Indicates an imminently hazardous situation that, if not avoided, **WILL** result in death or serious injury if proper precautions are not taken.



WARNING

Indicates a potentially hazardous situation that, if not avoided, **COULD** result in death or serious injury if proper precautions are not taken.



CAUTION

Indicates a potentially hazardous situation that, if not avoided, **MAY** result in minor or moderate injury if proper precautions are not taken, or, serves as a reminder to follow appropriate safety practices.



SAFETY

OPERATOR RESPONSIBILITY

Remember, YOU, the operator, are responsible for the safe operation, adjustment, maintenance and repair of this PhiBer® Large Square Bale Accumulator. It is the responsibility of the owner, or authorized person in charge, to ensure all persons who operate, adjust, maintain and/or repair this implement be familiar with the information provided in this Operator's Manual.

A safe operator is the key to safety. Good safety practices not only protect you, but also persons who may be in the vicinity of the accumulator. Make good safety practices a part of your farming operation. Ensure that all persons operating, adjusting, maintaining and/or repairing this equipment are familiar with the procedures recommended in this Operator's Manual.

Always heed safety warnings and follow recommended safety precautions to avoid hazardous situations. Do not risk personal injury or death by ignoring safety warnings and safety precautions.

Key Safety Reminders:

- The most important safety device is a safe and qualified operator.
- A safe operator is one who has read and understood the contents of the Operator's Manual prior to performing any tasks related to the machine.
- Owners have a responsibility to provide training to persons who may operate, adjust, maintain and/or repair the equipment prior to performing any of these tasks.
- Do not perform any unauthorized modifications to the accumulator or use the accumulator for any purpose other than what is described in the contents of this Operator's Manual.
- Plan tasks and work schedules to reduce exposure to unnecessary stress and fatigue.
- Observe all workplace safety and health requirements.

GENERAL SAFETY PRACTICES

- Read and understand the contents of this Operator's Manual prior to operating, adjusting, maintaining and/or repairing the bale accumulator.
- Locate, read and understand all safety signs applied to the accumulator before performing any tasks.
- Review the contents of this Operator's Manual at least annually, and, any time a new person is assigned to perform any task with the accumulator.
- Ensure that all bystanders, especially small children, are kept at a safe distance while performing any tasks with the accumulator.
- Do not allow riders on any part of the accumulator.
- Ensure all guards and shields are intact and in place prior to operating the accumulator.
- Keep hands, feet, hair and loose clothing away from moving and/or rotating parts.
- Stop the engine, lower the equipment, set the parking brake, remove the ignition key, and allow time for moving parts to stop prior to adjusting, maintaining or repairing the equipment.
- Ensure that all equipment lighting and marking is intact, clean and operating properly prior to traveling on public roads. Check with local highway authorities to confirm accumulator is properly equipped for highway travel.
- Provide a fully stocked First-Aid kit in a highly visible and easily accessible location.
- Keep a fully charged fire extinguisher in a highly visible and easily accessible location.
- Ensure that accumulator is securely blocked and supported prior to working underneath, if it needs to be raised for service.

SAFETY

MAINTENANCE SAFETY

- Read and understand all of the information provided in this Operator's Manual covering the operation, adjustment, maintenance and repair prior to performing any of these tasks.
- Plan work to ensure proper tools, equipment and personal protective equipment are available prior to working on the accumulator.
- Wear appropriate clothing when performing tasks around the accumulator. Ill-fitting and/or frayed clothing as well as loose or dangling items should not be worn when working near the equipment.
- Stop the engine, lower the equipment, set the parking brake, remove the ignition key, and allow time for moving parts to stop prior to adjusting, maintaining or repairing the equipment.
- Ensure that all moving parts have come to a complete stop before performing adjustments, maintenance or repairs.
- Ensure that hydraulic oil pressure in hoses, lines and components is fully relieved prior to performing maintenance or repairs to the hydraulic system.
- Ensure that wings are either fully lowered or fully raised and secured with their safety chains or securely block the wings if raised to perform adjustment, maintenance or repairs.
- Securely block main frame if adjustment, maintenance or repair is required for wheels and tires.
- Wear personal protective equipment, such as gloves, eye protection, etc. when inspecting hydraulic system for leaks. Use a small piece of cardboard or wood to detect leaks.
- Ensure that all guards and shields are intact and in place after performing adjustment, maintenance or repairs prior to operating equipment.
- Store flammable fluids in approved containers and store out of access by unauthorized persons, especially children.

HYDRAULIC SAFETY

- Ensure that all hydraulic system components are kept clean and in proper working condition.
- Periodically inspect condition of hydraulic hoses, lines and components and remove and replace any parts showing damage or deterioration.
- Use only repair or replacement parts specified by the manufacturer.
- Make repairs following instructions provided by the manufacturer.
- Wear appropriate personal protective equipment when unsure if residual pressure may exist in hydraulic components during trouble-shooting and or making repairs.
- Use a piece of cardboard or wood to check for hydraulic leaks. Hydraulic fluid under pressure can penetrate human skin.
- Ensure all fittings, couplings and other hydraulic connections are intact and properly tightened before operating hydraulics.
- Ensure that all persons operating, adjusting, maintaining and/or repairing the accumulator know how to seek or summon medical assistance should an injury occur.

INSTALLATION SAFETY

- Read, review and understand all bale accumulator installation instructions before attempting to attach accumulator to baler.
- Ensure that baler is properly hitched to tractor and that baler is lowered fully to the ground.
- Ensure that tractor engine is shut off, key is removed from the ignition and that parking brake is set and/or wheels blocked.
- Block bale accumulator tires and support the front end of the bale accumulator frame until the accumulator is securely attached to the baler.

SAFETY

TRANSPORT SAFETY

- Ensure that the accumulator is attached to the baler properly.
- Ensure drawbar hitch pin retainer for baler is in place and engaged properly.
- Ensure safety tow chain is securely attached between baler and tractor.
- Ensure all lighting and implement marking devices are intact and visible.
- Ensure equipment is properly marked according to local road regulations and heed all local traffic regulations.
- Accumulator adds length to baler and covers a wide path when making turns.
- Ensure accumulator is fully unloaded before road travel.
- Do not exceed 32 km/h (20 mi/hr).
- Reduce travel speed on rough roads and surfaces.
- Do not allow riders on the accumulator at any time.

STORAGE SAFETY

- Store the accumulator away from areas of human activity.
- Do not allow children to play on or around accumulator

TIRE SAFETY

- Ensure tire inflation pressure is maintained per specifications.
- Follow proper procedures for tire repairs, especially when mounting tire to rim.
- Seek assistance from a trained person for tire repairs or mounting, especially if special equipment is required.

SAFETY SIGNS

SAFETY SIGN LOCATION (FIG. 6)

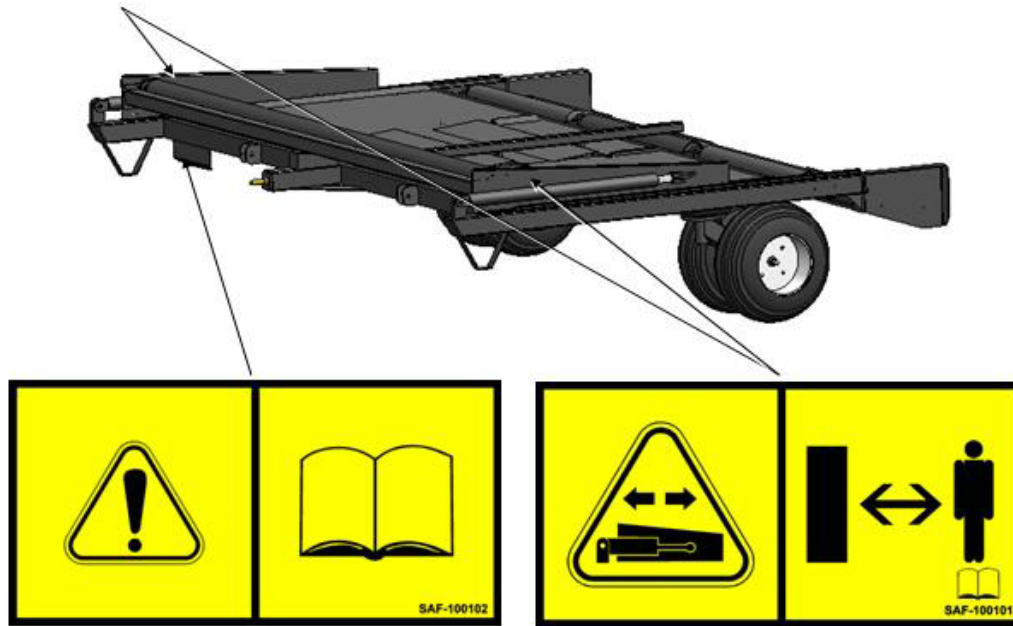

SAFETY SIGN EXPLANATION FIG. 6

READ THE OPERATOR'S MANUAL (FIG. 7)

WARNING! Read and understand the contents of the Operator's Manual before performing any tasks related to the operation, adjustment, maintenance or repair of the machine.



FIG. 7

MOVING PART HAZARD (FIG. 8)

WARNING! MOVING PART HAZARD. Keep all persons at a safe distance while machine is in operation or when making adjustments and/or repairs.



FIG. 8

SAFETY

SAFETY SIGN MAINTENANCE

Safety Sign Legibility

All safety signs applied to the accumulator must be visible and legible. Keep dust and dirt cleared from safety signs and ensure that visibility is not obscured.

Safety Sign Replacement

Replacement safety signs may be ordered through your dealer or distributor. Contact PhiBer® if you are unable to obtain replacement safety signs from a dealer or distributor.

Damaged or Deteriorated Safety Signs

Remove and replace any safety signs that have either damaged or show signs of deterioration.

Safety Signs on Replacement Parts

Ensure that parts or components that are replaced on the accumulator that had a safety sign attached originally include a safety sign.

Affixing Safety Signs to Machine

1. Ensure proper position and orientation before installing.
2. Ensure installation area is clean and dry.
3. Ensure ambient temperature is above 10° C (50° F).
4. Remove backing material to expose label adhesive.
5. Place one edge of label to machine surface.
6. Slowly press the label onto the surface.
7. Ensure no air pockets exist under surface of label.

SPECIFICATIONS

Bale Accumulator

	<u>AC3104</u>	<u>AC4104</u>
Bale Capacity	3	3
Bale Size	32 in (0.81 m)	48 in (1.22 m)
Bale Ejection	Manual or Automatic	Manual or Automatic
Width	116 in (2.95 m)	162 in (4.11 m)
Length	110 in (2.79 m)	110 in (2.79 m)
Height	38 in (0.96 m)	38 in (0.96 m)
Wheels	4 - 26x12.00-12NHS	4 - 26x12.00-12NHS
Electrical Power Supply	12 V	12 V
Hydraulics	10 gal/min (37.8 L/min) continuous flow	10 gal/min (37.8 L/min) continuous flow
Bale Length (range)	4.5 - 9 ft (1.37 - 2.74 m)	4.5 - 9 ft (1.37 - 2.74 m)
Silage Bale Handling	Yes	Yes

Tractor Requirements

Hydraulics	
# of circuits required	1
hydraulic flow	9 - 12 gal/min (34.1 - 45.4 L/min)
Electrical Power Supply	12 V

SPECIFICATIONS

Hardware Torque

SAE

Bolt Diameter	Bolt Torque		
	SAE 2 n-m (lb-ft)	SAE 5 n-m (lb-ft)	SAE 8 n-m (lb-ft)
inches			
1/4	8 (6)	12 (9)	19 (12)
5/16	13 (10)	25 (19)	36 (27)
3/8	27 (20)	45 (33)	63 (45)
7/16	41 (30)	72 (53)	100 (75)
1/2	61 (45)	110 (80)	155 (115)
9/16	95 (70)	155 (115)	220 (165)
5/8	128 (95)	215 (160)	305 (220)
3/4	225 (165)	390 (290)	540 (400)
7/8	230 (170)	570 (420)	880 (650)
1	345 (225)	850 (630)	1320 (970)

Metric

Bolt Diameter	Bolt Torque	
	8.8 n-m (lb-ft)	10.9 n-m (lb-ft)
mm		
M3	0.5 (0.4)	1.8 (1.3)
M4	3 (2.2)	4.5 (3.3)
M5	6 (4)	9 (7)
M6	10 (7)	15 (11)
M8	25 (18)	35 (26)
M10	50 (37)	70 (52)
M12	90 (66)	125 (92)
M14	140 (103)	200 (148)
M16	225 (166)	310 (229)
M20	435 (324)	610 (450)
M24	750 (555)	1050 (774)
M30	1495 (1103)	2100 (1550)
M36	2600 (1917)	3675 (2710)

Flare-Type Tube Fittings

Tube Size OD	Nut Size across flats	Torque	Recommended # Turns (after finger tightening) turns (flats)
in	in	n-m (lb-ft)	
3/16	7/16	8 (6)	1/6 (1)
1/4	9/16	12 (9)	1/6 (1)
5/16	5/8	16 (12)	1/6 (1)
3/8	11/16	24 (18)	1/6 (1)
1/2	7/8	46 (34)	1/6 (1)
5/8	1	62 (46)	1/6 (1)
3/4	1-1/4	102 (75)	1/8 (0.75)
7/8	1-3/8	122 (90)	1/8 (0.75)

NOTE: Torque values listed are based on lubricated connections in reassembly.

ACCUMULATOR HYDRAULICS

Proper set-up of tractor hydraulics ensures optimum operation of Bale Accumulator and can greatly increase system reliability. The hydraulic system on this Bale Accumulator is designed to function with open-center, closed-center and closed-center load-sensing tractor hydraulic systems. For tractors configured with closed-center hydraulic systems, some adaptation may be required to achieve optimum performance. Contact your dealer or PhiBer for assistance.

There are two crucial elements that must be heeded to ensure optimum Bale Accumulator performance:

1. Tractor hydraulic output flow must be set between 9 and 12 gal-US/min (34.0 - 45.4 L/min)

NOTE: Hydraulic oil flow in excess of 12 gal-US (45.4 L/min) may cause hydraulic lock up of the system. Flow rates below 9 gal-US (34.0 L/min) will cause lower cycle times and can impede productivity.

2. The low pressure tank return line must discharge directly into the tractor hydraulic reservoir with negligible system back pressure.

NOTE: Newer model tractors may have a setting on the hydraulic couplers remote connection that directs return oil flow straight to the tractor hydraulic reservoir. Other tractors may be fitted with an external port that leads directly to the tractor hydraulic reservoir. DO NOT connect the tank return line so that return oil flow must work against pilot operated check valves in the tractor hydraulic system.

OPERATION

COMPONENT CYCLE TIMES

Component / Action 12 gal-US/min (45.4 L/min) flow rate	Model 3104 (sec)	Model 4104 (sec)
Side Truck: R/H side to L/H side	4	6
Side Truck: L/H side to R/H side	4	5
Push Off Truck: extend and retract	7 (4 ext / 3ret)	7 (4 ext / 3ret)

CYCLE INITIATION

This start-up or cycle initiation procedure ensures that both the bale eject and bale side shift trucks are in their respective “home” positions and hydraulic cylinders are fully retracted before operating the Bale Accumulator in the field.

 **WARNING! MOVING PART HAZARD.** Ensure that the deck of the accumulator is clear of any foreign objects and that all bystanders are at a safe distance before starting the tractor, baler and the Bale Accumulator.

1. Start tractor engine and activate tractor hydraulic system.
2. Toggle power switch on monitor panel to “ON”.
3. Press the “EJECT” button on the monitor panel.
4. Allow 10 seconds to elapse before using the Bale accumulator to ensure both the push off and side shift trucks have returned to their “home” positions.

OPERATION

CYCLE MODE SELECTION

The PhiBer® Bale Accumulator allows the operator to select among four (4) bale ejection modes (FIG. 6):

- A 3 bales default mode
- B 2 bales side-by-side
- C 2 bales gap between bales
- D 1+3 bales delayed eject

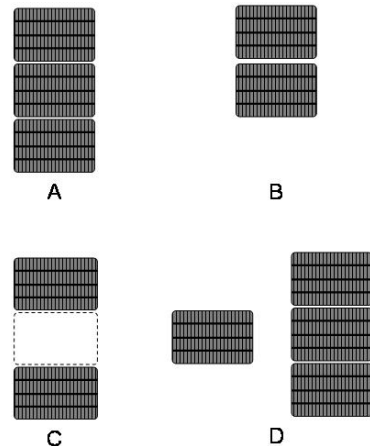

FIG. 6

After the tractor has started and the accumulator cycled:

1. Press and hold the “EJECT” button, 1, FIG. 7.
2. NOTE: Push-off truck will cycle and return to “home” position and indicator lights on panel will flash.
3. Release “EJECT” button.
4. Press “EJECT” button to select bale ejection mode:

- 0 x 3 bales (default)
- 1 x 2 bales (side-by-side)
- 2 x 2 bales (with gap)
- 3 x 1+3 bales (delayed eject)

5. After 5 seconds, the selected bale eject mode will be stored in memory as displayed.

NOTE: Accumulator function may be bypassed by toggling the power switch to “OFF”. This allows bales to eject from baler and roll off accumulator deck to the ground.



FIG. 7

OPERATION

FIELD OPERATION

AUTOMATIC BALE EJECTION

Once the Bale Accumulator has been started, cycled and bale ejection mode selected, the accumulator will function automatically. If the chamber on the baler is empty at the beginning of the baling process, toggle the accumulator power switch to “OFF”. As soon as a solidly formed bale has formed in the chamber, the power switch should be toggled “ON” and the “EJECT” button pressed for cycle initiation. The bale ejection mode can be modified by the operator at any time by following the CYCLE MODE SELECTION procedures.

MANUAL BALE EJECTION

Windrow Formation

The operator can form rows of bale packages at any desired place in the field by pressing the “EJECT” button at the desired drop location. The Accumulator will unload all finished bales on deck at that point. Automatic accumulation will resume if “EJECT” button is not used.

Bales Ejected at Headlands

Bales can be placed at the ends of a field by pressing the “EJECT” button before or after turning at headlands. Do not eject while turning. The “delayed eject” mode can be used when gathering bales at headlands. In this mode the Accumulator will fill up but not eject immediately. Indicator lights will show the number of bales on deck. When deck is full the operator will interrupt the baling process and drive to the desired drop location where the bales can be unloaded by pressing “EJECT”. Alternately, when operating in the “delayed eject” mode the accumulator will drop a single bale (the third bale in the accumulation cycle). When the following bale drops onto the accumulator deck, a package of three bales will be ejected onto the ground. This mode may conveniently be used in irrigated fields, where gathering bales at headlands is critical. The “delayed eject” mode allows the package of three bales to reach the headlands and a single bale to drop in the field, rather than vice versa.

NOTE: By toggling the power switch “OFF” and then “ON” again, the Bale Accumulator cycle mode returns to the default or three (3) bale accumulation setting. Follow the CYCLE MODE SELECTION procedure if a different bale accumulation cycle is desired. DO NOT eject bales while making any turns.

BALE TRIGGER ADJUSTMENT

The bale trigger mechanism senses a bale entering the accumulator deck from the baler and activates the side shift truck function. The side shift truck may cycle prematurely if the bale trigger spring tension is set too loose, the bale trigger button is set too high or the bale trigger button is set too close to the baler.

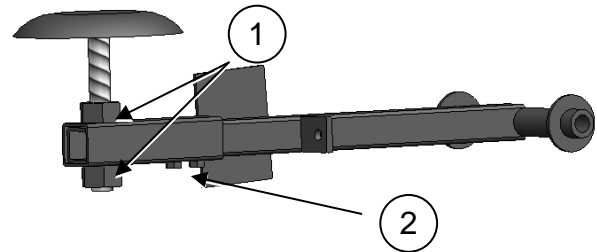

FIG. 8

BALE TRIGGER VERTICAL ADJUSTMENT

1. Loosen nuts, 1, FIG. 8, on threaded rod.
2. Turn bale trigger button and threaded rod until reaching desired vertical position.
3. Tighten nuts on threaded rod.

BALE TRIGGER HORIZONTAL ADJUSTMENT

1. Loosen nuts, 2, FIG. 8, on telescoping tube.
2. Slide tube forward or rearward to desired position.
3. Tighten nuts.

NOTE: Loosely packed or silage bales may sag and contact bale trigger button causing the side shift truck to cycle prematurely.

OPERATION

TRANSPORTING

⚠ WARNING! Unload all bales from accumulator deck before traveling on public roads.

⚠ WARNING! WIDE TURNING PATH. Ensure that all oncoming and/or overtaking traffic is clear before making turns on public roads. Slow down and look for both oncoming and overtaking traffic before making turns.

Always travel on public roads with the Bale Accumulator in the lane of travel, FIG. 9.

Allow oncoming and overtaking traffic to clear before making turns when traveling on public roads, FIG 10.

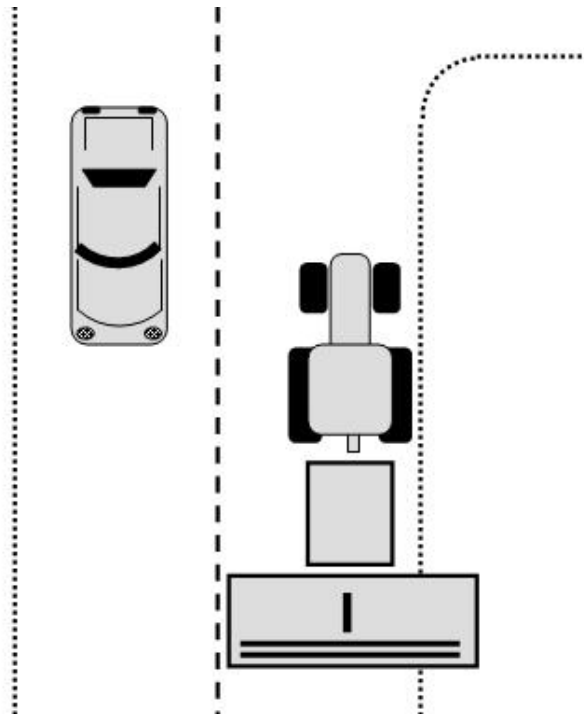

FIG. 9

STORAGE

⚠ WARNING! Store Bale Accumulator away from human activity. DO NOT allow children to play on the Bale Accumulator at any time.

To ensure optimum operation of the Bale Accumulator for the next season:

1. Clean all crop material and dirt from Bale Accumulator frame and deck.
2. Retract hydraulic cylinders fully.
3. Lubricate casters to prevent rusting.
4. Lubricate bearings in rollers.

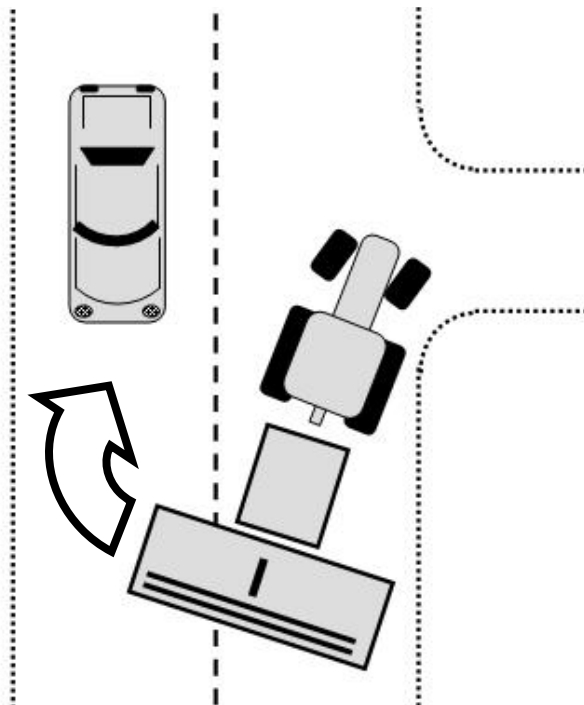

FIG. 10

MAINTENANCE

ROUTINE MAINTENANCE

Proper maintenance of the accumulator will result in more reliable performance. Please refer to the chart below for recommended maintenance information:

KEY		MAINTENANCE RECORD											
✓	check	hours											
●	lubricate	by											
◇	clean	date											
▲	change												
12 ⌘													
●	Casters												
✓	Limit Switches												
✓	Wheel Lug Nuts												
50 ⌘													
●	Roller Bearings												
●	Hitch Pivot												
✓	Bale Trigger Spring Tension												
1000 ⌘													
✓	Wheel Lug Nuts												
●	Wheel Bearings												

CASTERS

Grease casters, 1, FIG. 11 every 12 hours or daily (2 fittings).

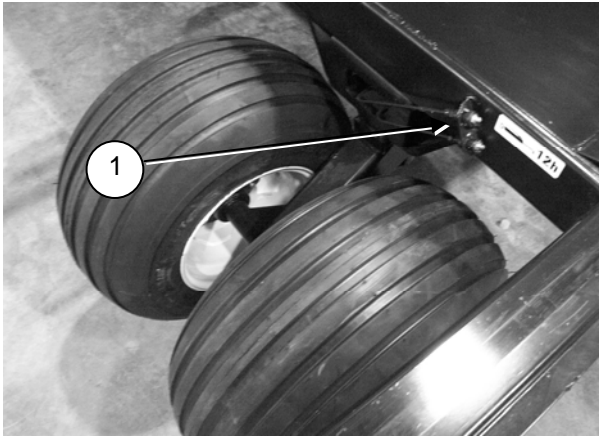

FIG. 11

MAINTENANCE

LIMIT SWITCHES

Check the limit switches, 1, FIG. 12 daily to ensure they are clear of accumulation of foreign material.

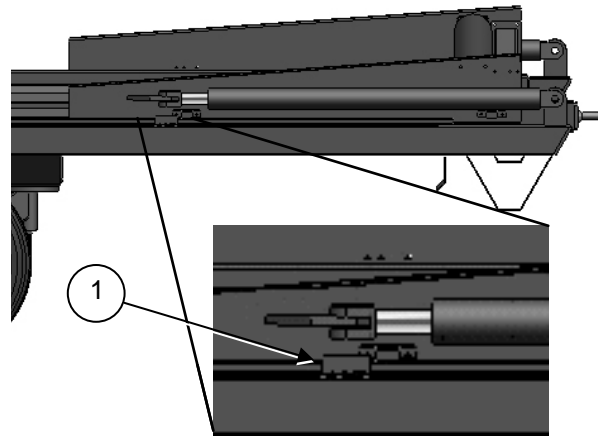

FIG. 12

WHEEL LUG NUTS

Check wheel lug nut 1, FIG. 13 tightness after the first two (2) hours of operation, again after the first ten (10) hours, then periodically.

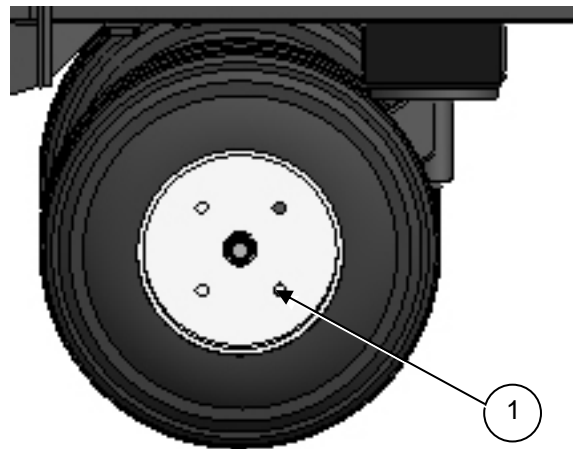

FIG. 13

ROLLER BEARINGS

Grease roller bearings, 1, FIG. 14 every 50 hours or weekly (12 fittings plus 2 additional fittings if front roller option is installed).

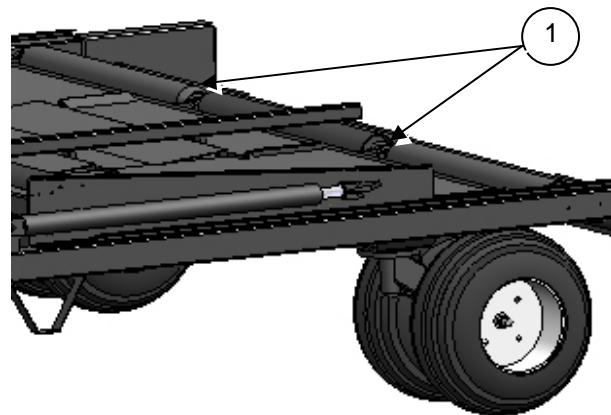

FIG. 14

MAINTENANCE

HITCH PIVOT

Grease hitch pivot, 1, FIG. 15 every 50 hours or weekly.

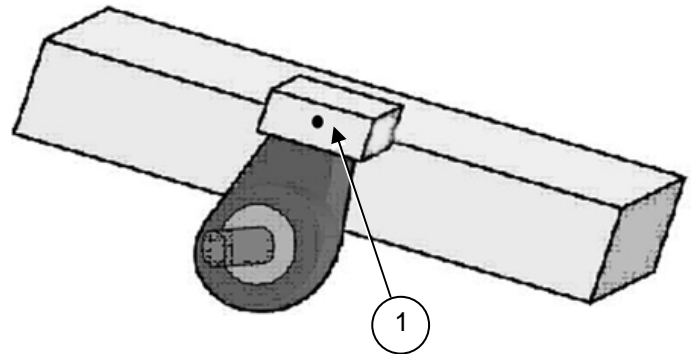

FIG. 15

BALE TRIGGER SPRING TENSION

Check bale trigger spring tension, FIG.16, every 50 hours or weekly. Adjust, if necessary.

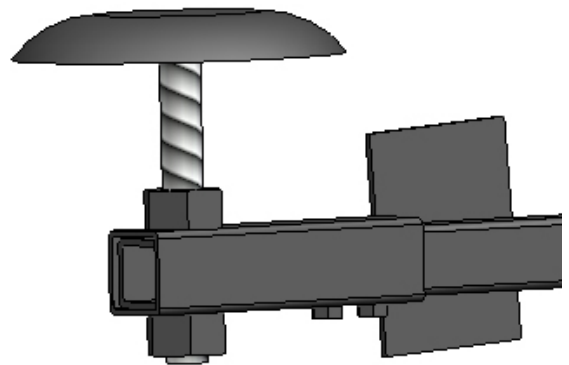

FIG. 16

WHEEL BEARINGS

Remove, clean and re-pack wheel bearings, FIG. 17, every 1000 hours or annually.

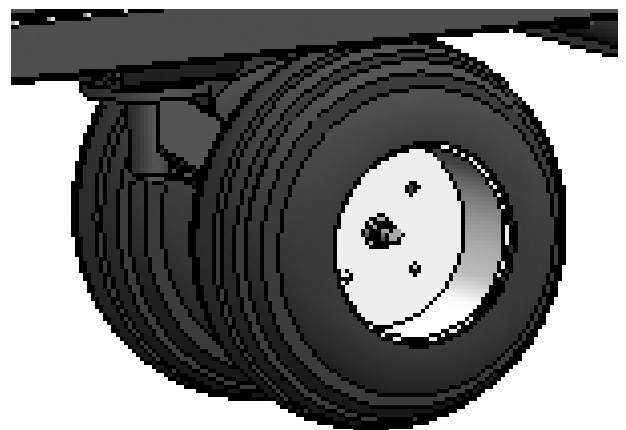

FIG. 17

MAINTENANCE

HYDRAULIC CYLINDER REPLACEMENT

NOTE: The following procedure must be followed in order to remove air from the hydraulic system if a hydraulic cylinder is ever removed and replaced.



WARNING! Unexpected Motion Hazard. Ensure all bystanders are clear of the deck and tracks during this air removal procedure.

1. Disconnect rear pin from push-off master and slave cylinder and support cylinders away from push-off truck.
2. Lock push-off limit switch in its “home” (lever forward) position.
3. Activate hydraulic control valve to allow oil to flow.
4. Toggle power switch on monitor panel to “ON”. Lights will strobe.
5. Press “EJECT” button on monitor panel. Master cylinder will begin to fill followed by the slave cylinder.
6. After 20 seconds hydraulic flow will cease and cylinder extension will stop. Press “EJECT” button to resume filling of cylinders. Repeat this step until cylinders are fully extended.

7. Unlock push-off limit switch and momentarily move switch lever rearward and release allowing it to return to center. Cylinders will then retract to their “home” position.
8. Lock push-off limit switch into “home” position. Side shift cylinder will begin to fill and move to its “home” position.
9. Both hydraulic cylinders should retract fully. If not, repeat 5-8.
10. Toggle power switch on monitor panel to “OFF”.



WARNING! UNEXPECTED MOTION HAZARD. Ensure power switch is toggled “OFF” before re-attaching hydraulic cylinder.

11. Replace push-off cylinder rear pins connecting them to the push-off truck.
12. Toggle power switch to “ON”.
13. Press “EJECT” button to initiate accumulator function.



WARNING! MOVING PART HAZARD. Use caution when activating bale trigger. DO NOT stand on deck to activate bale trigger.

14. Pull the bale trigger arm downward from below the deck to test bale accumulator function.

MAINTENANCE

HYDRAULIC CIRCUIT

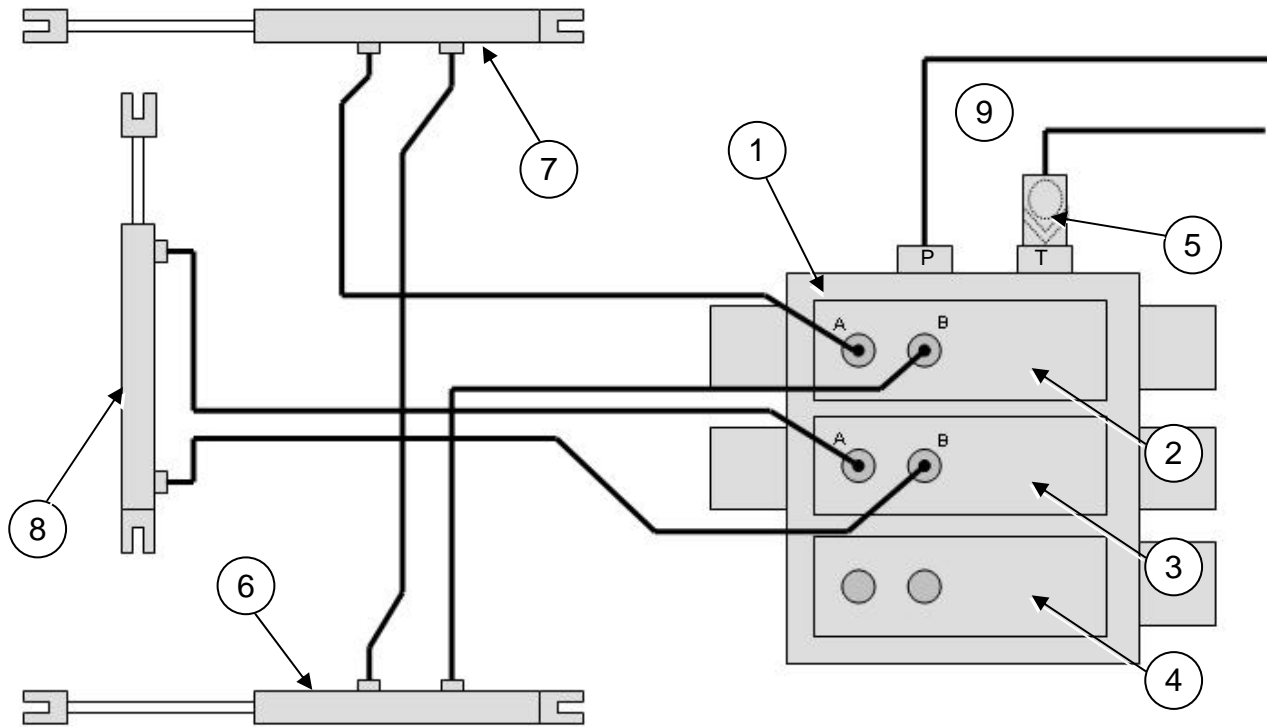

FIG. 18

FIG. 18

Item	Description
1	Solenoid Control Valve
2	Eject Valve
3	Side Shift Valve
4	Open Center Valve
5	Check Valve
6	Eject Cylinder - Master
7	Eject Cylinder - Slave
8	Side Shift Cylinder
9	Hydraulic Oil to/from Tractor
P	"Pressure" port on valve
T	"Tank" port on valve

ELECTRICAL SCHEMATIC

ACCUMULATOR CONTROLS

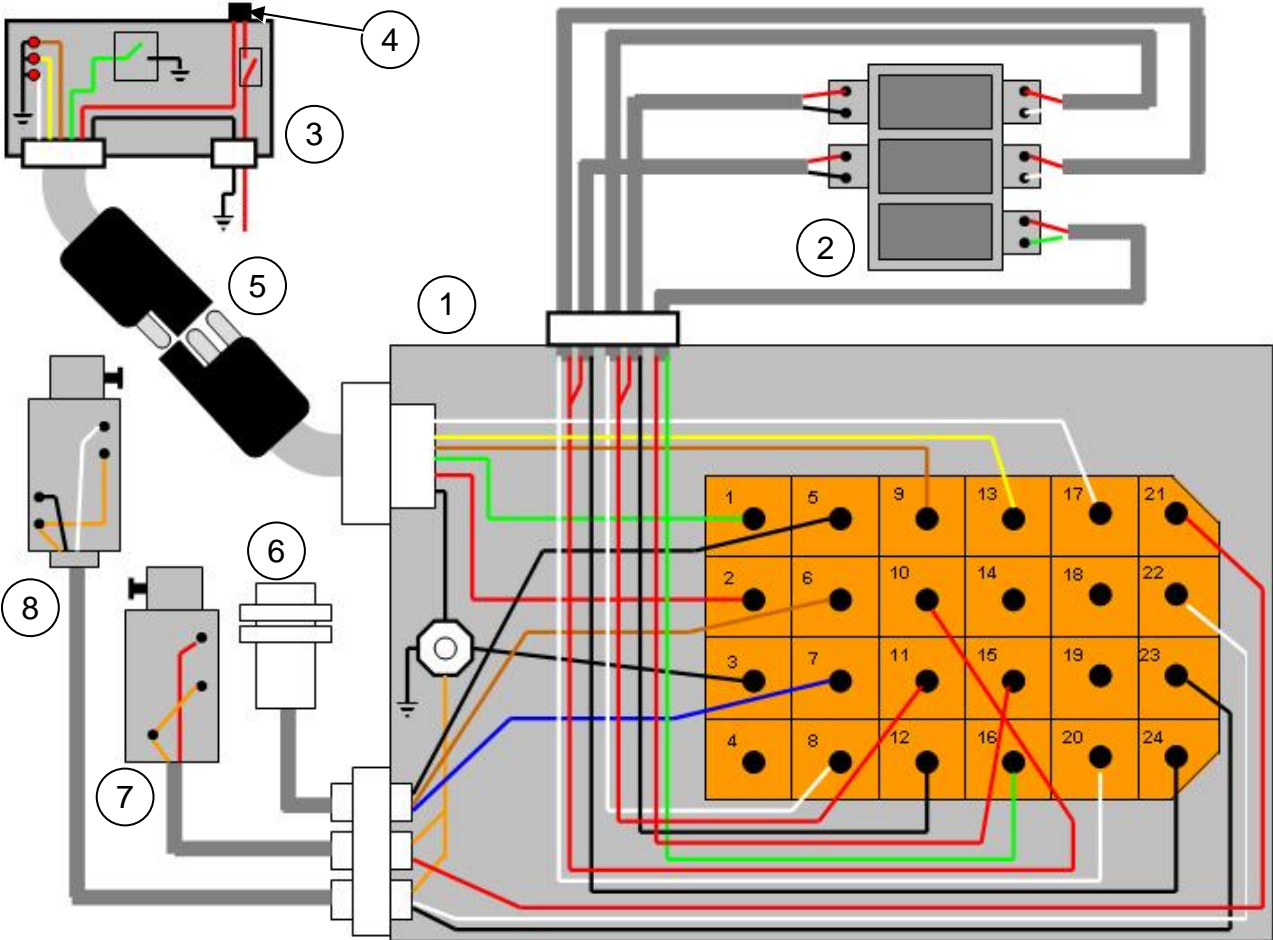

FIG. 19

FIG. 19

Item	Description
1	Accumulator Control Box
2	Solenoid Control Valve
3	Operator Control Box
4	Fuse (7 A)
5	Electrical Harness Connector
6	Bale Button Proximity Switch
7	Side Shift Limit Switch
8	Bale Eject Limit Switch

MAINTENANCE

LIGHTING AND MARKING

FIG. 20

Item	Description
1	Harness Connector
2	Tail Lights
3	Left Hand Flasher
4	Right Hand Flasher

NOTE: Wiring harness wire colors may vary depending on make and model of baler.

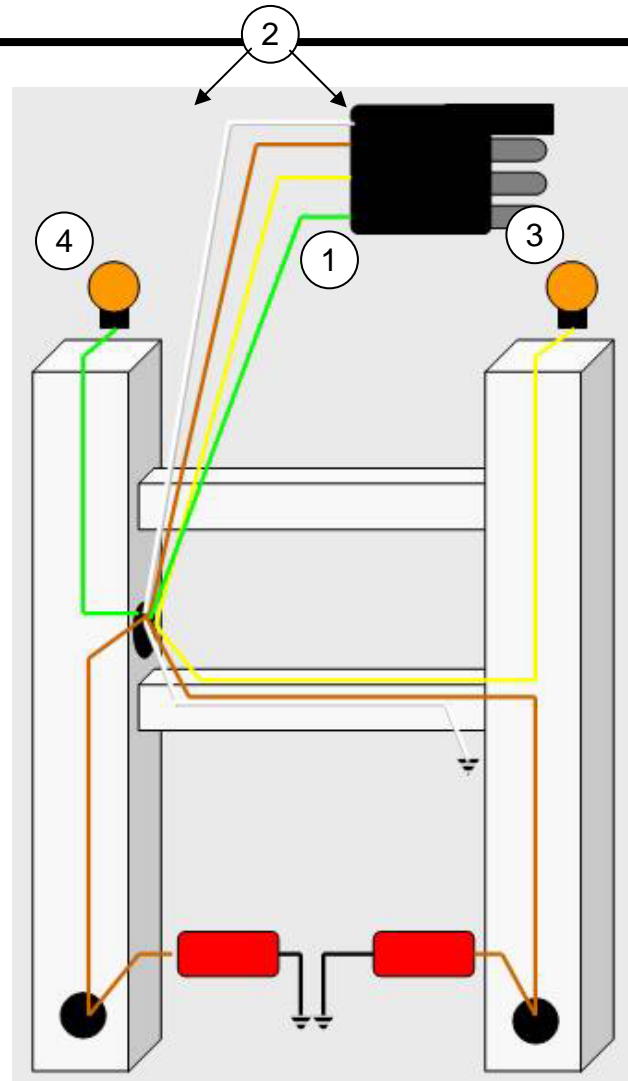

FIG. 20

TROUBLE-SHOOTING

SYMPTOM	POSSIBLE CAUSE	SOLUTION
<p>Side shift and push off trucks do not move when tractor hydraulic lever actuated.</p>	<p>Hydraulic hose connections reversed.</p> <p>Poor electrical connection.</p> <p>Fuse blown.</p> <p>Improper limit switch setting.</p> <p>Electronic monitor malfunction.</p>	<p>Change hose connections at tractor hydraulic quick couplers.</p> <p>Inspect the wiring harness coupling and clean, if necessary.</p> <p>Remove and replace 7 A fuse on monitor in tractor cab.</p> <p>Check settings on limit switches for side shift and push off modes. Adjust, if necessary.</p> <p>Toggle power switch to "OFF", then press and hold "EJECT" button for 3 seconds to clear and reset memory. Indicator lights will strobe when power is resumed to indicate proper operation.</p>
<p>Side shift operates prematurely.</p>	<p>Bale trigger bounces on rough terrain.</p> <p>Bales sag as they leave the chamber on the baler.</p>	<p>Tighten spring on bale trigger.</p> <p>Adjust bale trigger downward to make less sensitive.</p> <p>Adjust bale trigger forward for haylage bales.</p> <p>Raise front of accumulator.</p>
<p>Push off truck moves slightly after resetting accumulator even if other tractor hydraulics appear to be functioning properly.</p>	<p>Hydraulic lock.</p> <p>Hydraulic lock.</p> <p>Hydraulic lock.</p>	<p>Place tractor hydraulic control lever in float position or disconnect return hydraulic hose coupler to drain off excessive oil. Push center pins of main valve until all pins move freely. Re-connect hydraulic hose coupler.</p> <p>Ensure that return oil is discharging into tractor hydraulic reservoir.</p> <p>Reduce tractor hydraulic flow to accumulator to 12 gal-US/min (45.4 L/min) or less.</p>

TROUBLE-SHOOTING

SYMPTOM	POSSIBLE CAUSE	SOLUTION
Bale trigger does not activate side shift truck.	Gap between proximity switch and trigger plate is too large.	Measure gap between proximity switch and trigger plate. Adjust gap, if necessary. Proper gap setting is between 3/16 - 1/8" (1.5 - 3 mm).
Electronic system appears inactive. Indicator lights do not strobe at start-up.	Blown fuse on circuit board.	Toggle power switch to "OFF". Open control box under deck of accumulator, remove and replace 800 mA fuse. Toggle power switch back to "ON".
Tractor hydraulic oil overheating.	<p>Tractor hydraulic oil flow set too high.</p> <p>Low pressure return oil flow is not discharging into tank properly.</p>	<p>Reduce tractor hydraulic oil flow setting.</p> <p>Ensure that low pressure return flow is discharging directly into the tractor hydraulic reservoir. Newer tractor hydraulic systems have provisions for setting oil flow return directly into the tractor reservoir. With older model tractors, it may be necessary to plumb return flow to a port or fitting to allow direct discharge into the reservoir.</p> <p>Remove and inspect check valve. Clean out any debris and replace check valve.</p> <p>Inspect quick coupler tips for proper action and/or blockage.</p>

HITCH KIT MOUNTING GUIDELINES

All PhiBer Bale Accumulator hitch kits are similar in design, but each specific baler make and model require certain specific hitch parts. All hitch kits consist of three main sets of components:

1. Center mount hitch assembly that carries the weight of the accumulator.
2. Pair of link arms with associated hardware for towing the accumulator.
3. Bale support system that supports oncoming bales during bale ejection.

NOTE: All PhiBer® Bale Accumulators are shipped with a complete set of installation instructions. The information provided here are some guidelines for preparing the baler for installation of the Bale Accumulator.

Read, understand and follow all installation instructions prior to installing the Bale Accumulator onto the baler. Failure to follow these instructions may result in improper Bale Accumulator installation and the Bale Accumulator may not perform as intended.

PREPARE TRACTOR AND BALER

1. Hitch baler to tractor per instructions found in baler Operator's Manual.
2. Park tractor and baler on firm, level surface.
3. Shut tractor engine off and remove key from ignition.
4. Set tractor parking brake.
5. Support bale chute securely and remove retaining hardware.
6. Carefully lower bale chute to the ground and move it away from the baler.

INSTALLATION

GENERAL INSTALLATION TIPS

Accumulator Placement

Ensure that the Bale Accumulator, 1, FIG.21, is mounted squarely to the rear of the baler, 2, FIG. 21 as shown. Begin installation procedures with Bale Accumulator set on a firm, level surface behind the baler. The deck should be evenly spaced behind the baler.

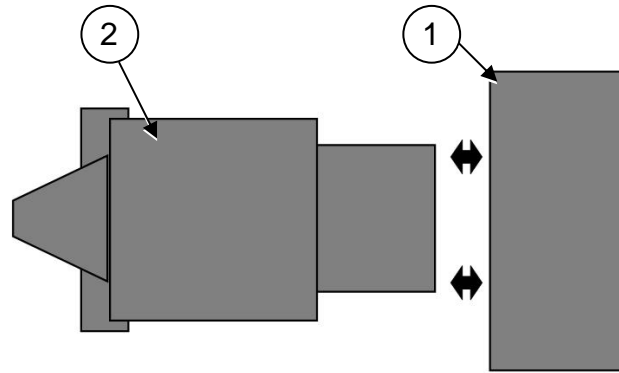

FIG. 21

After-Market Baler Attachments

Check for potential interference with any after-market baler attachments such as bale ejectors, preservative tanks, etc. Contact PhiBer if any modifications are necessary.

Optimum Hitch Height

The optimum hitch height is 25 in (635 mm) from the ground as shown in FIG. 22. This is important so that the leaf springs, 1, FIG.23, do not become over stressed as indicated by the dashed line.

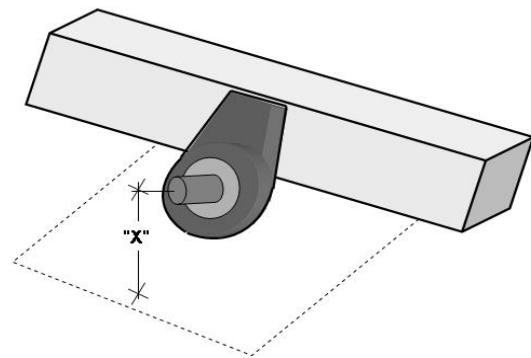

FIG. 22

NOTE: Hitch height may range from 23 in (584 mm) to 29 in (736 mm) to allow for differences in baler makes and models.

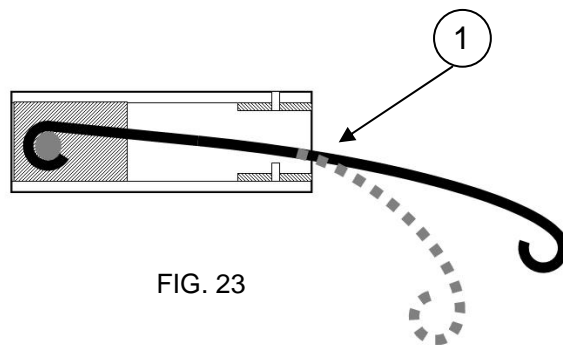

FIG. 23

INDEX

<u>A</u>		<u>H</u>	
Accumulator controls	29	Hitch kit mounting guidelines	33
Accumulator placement	34	Hitch pivot	25
Assembly, bale accumulator	5	Hydraulic circuit	28
		Hydraulic cylinder replacement	26
<u>B</u>		Hydraulics, accumulator	17
Bale ejection, automatic	20		
Bale ejection, manual	20	<u>I</u>	
Baler attachments, after-market	34	Indicator lights	6
Bale trigger	5	Installation	34
Bale trigger adjustment	21		
Bale trigger spring tension	25	<u>L</u>	
Bearings, roller	24	Lighting and marking	30
Bearings, wheel	25	Limit switches	24
		Limit switch, bale eject	24, 29
<u>C</u>		Limit switch, side shift	24, 29
Casters	23	Lug nuts, wheel	24
Check valve	28		
Control box, accumulator	29	<u>M</u>	
Control box, operator	29	Maintenance	23
Cycle initiation	18	Maintenance, routine	23
Cycle mode selection	19	Maintenance, safety sign	14
Cycle times, component	18	Machine, illustration	5
Cylinder, hydraulic master - eject	28	Master cylinder	5
Cylinder, hydraulic slave - eject	28	Modes, bale packaging	4
Cylinder, side-shift	28	Monitor and controls	6
<u>D</u>		<u>O</u>	
Deck, accumulator	5	Open center valve	28
Description, machine	4	Operation	17
		Operator responsibility	8
<u>E</u>		Optimum hitch height	34
Eject button	6		
Eject valve	28	<u>P</u>	
Electrical schematic	29	Panel, monitor/control	6
		Power switch	6
<u>F</u>		Push-off limit switch	5
Field operation	20	Push-off roller	5
Fuse holder	6, 29	Push-off truck	5
<u>G</u>			
General installation tips	34		
General safety practices	9		

INDEX

S

Safety	7
Safety, hydraulic	11
Safety, installation	11
Safety, maintenance	10
Safety, storage	12
Safety, tire	12
Safety, transport	12
Safety alert symbols	7
Safety signs	13
Safety sign explanation	13
Safety sign maintenance	14
Serial number	6
Side-shift truck	5
Side shift valve	28
Signal words	7
Slave cylinder	5
Solenoid control valve	28, 29
Specifications	15
Storage	22

T

Torque, hardware	16
Transporting	22
Trouble-shooting	31



SAF-100750
Issued 01/2006

PhiBer Manufacturing Inc.
Crystal City, MB R0K 0N0
Canada

Printed in Canada