

# DASH



INNOVATIVE DESIGN • PARTNERS IN EFFICIENCY

# PHIBER



## Brilliantly Fast

*The design of the Dash has two primary objectives:*

1. Keep the sprayer spraying by reducing fill times
2. Keep chemicals separated



Choose a source for the rinse pump from either fresh water or the left inductor.

Each inductor can be fitted with an optional jug knife.



Every inductor automatically rinses itself down with every unload.

The unique linkage shuts the rinse off before the main valve. This allows for complete cleanout.

Choose a source for the rinse pump from either fresh water or the left inductor.

Pull handles allow you to completely load your sprayer from ground level.

Air Powered Diaphragm Pump is the heart of the rinsing system. This pump is used for rinsing jugs, inductors, getting dry chemicals into suspension, hand sprayer and wash down for easy cleanout.

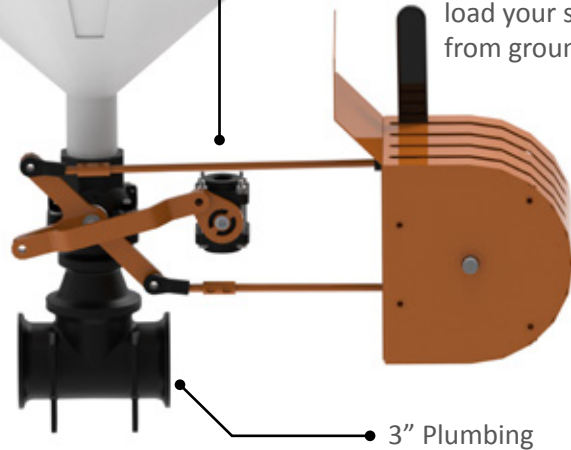
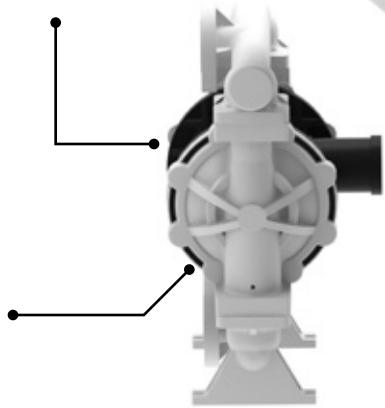

3" Plumbing

# DASH CONCEPT

The operator can stand at the side of the trailer completely loading the sprayer with up to four different products standing in one spot.



Manually turn on the rinse nozzle to wash out a jug or inductor.

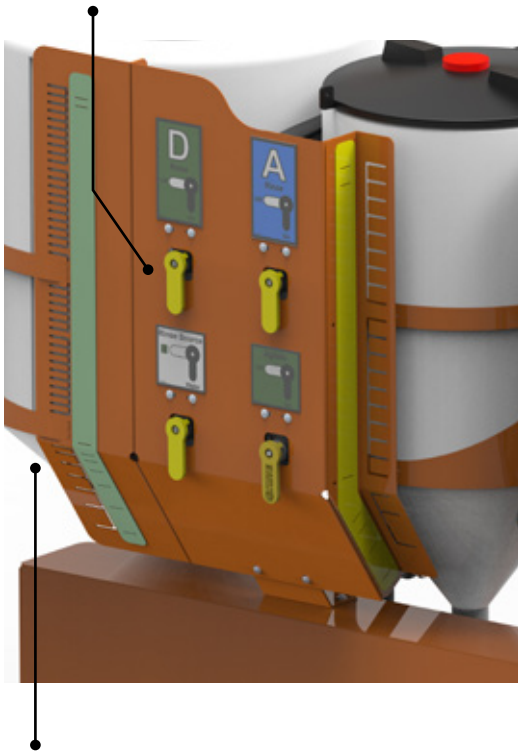

Accurately preload the inductors with chemicals using the easy to see indicator markings.



All inductors come with flip up lids.

Turn on agitate and get dry products into suspension.

All inductors have anti-vortex plates. This increases unloading speeds while reducing the amount of air being drawn into the water stream minimizing foaming.

# DASH 4.0



## Rear Mount Dash 4.0

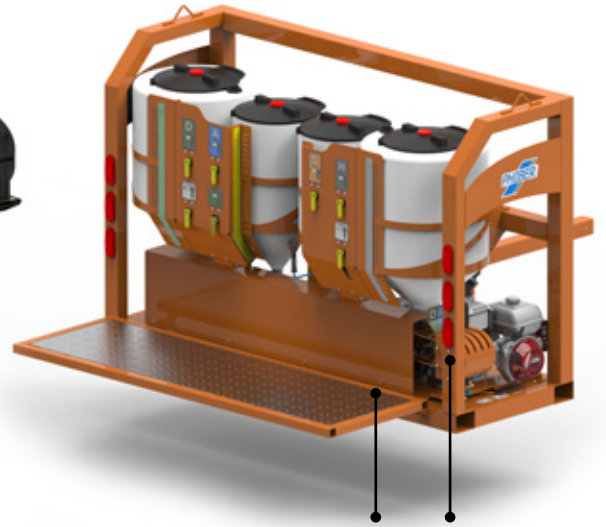

## Center Mount Dash 4.0

190 GAL total storage:  
65 GAL X 2  
30 GAL X 2

Rear mount includes tail lights and flip down deck

Easy to read indicators

Easy to use pull handles allow the operator to stand in one spot and unload inductors.

Comes standard with 13hp honda with electric start and hydro Pump.

Includes a 40 GPM air powered pump for rinsing Jugs or Inductors.



# DASH 2.0

*The Dash 2.0 has all the same great features as its big brother, just in a smaller package.*

Preload, Auto Rinse, agitate Dry Products and Easy Cleanout are at the core of its design.

Shown with optional 13hp honda with hydro Pump.



# DASH 2.0

Easy to read indicators

95 GAL total storage:  
65 GAL X 1  
30 GAL X 1

Includes a 24 GPM air powered pump for rinsing Jugs or Inductors.

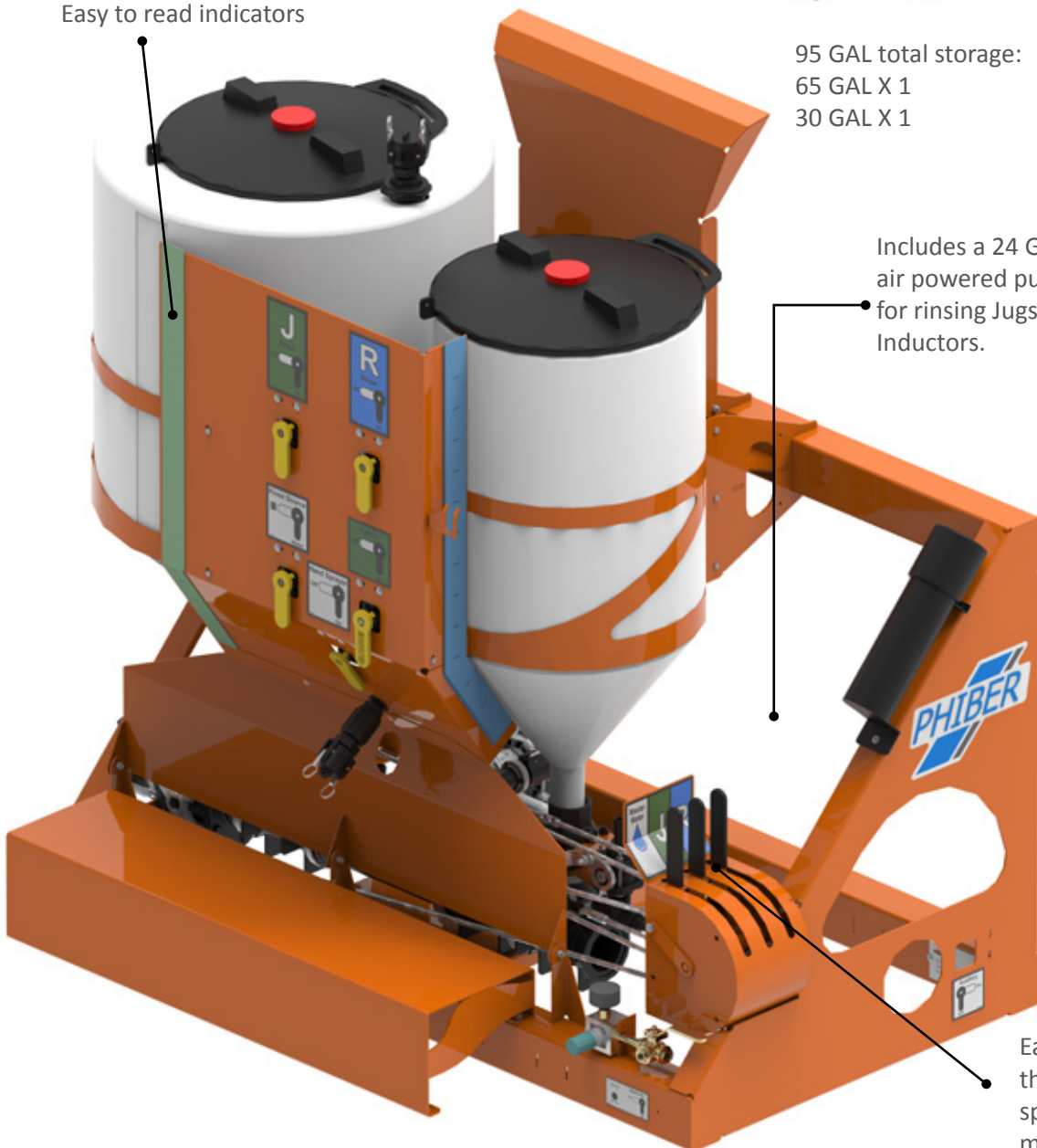

Easy to use pull handles allow the operator to stand in one spot and unload inductors or meter from bulk containers.

# DASH OPTIONS



### CHEMICAL TRANSFER PUMP 4.0 2.0

Powered by truck air, Teflon seals, 40gpm.



### 3" HOSE REEL 4.0 2.0

Electric and has a Stainless Steel Swivel. Holds 75' of hose.

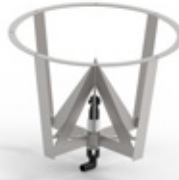

### JUG KNIFE KIT 4.0 2.0

Replace the standard inductor/jug rinse with a jug knife. Includes a patent tank/jug wash nozzle like standard inductors. Can be fitted in both inductors.

### CAGE WITH TOTE PLATFORM 4.0 2.0

Keep pallets of boxes contained while transporting. Load from either end or access from side door. store totes above on tote platform. Available in 5' or 6' high configurations.



### LIGHT KIT 4.0

Never work in the dark again. Includes mounting post and two LED flood lights.

### WORKING PLATFORM 4.0

Designed to mount to the Dash 4.0 to improve ergonomic comfort while loading jugs.



### TANKS 4.0 2.0

Includes hoops for mounting and internal baffles.

Capacity (Gal)	(W" x L" x H")
3250	88 x 146 x 79
3750	88 x 146 x 91
4250	88 x 146 x 101

**Complete Trailer Kits Available!**

### SPRAYER TRAILER OPTION



# DASH OPTIONS

## TOTE PLATFORM 4.0

Designed to mount to the Dash to store totes above inductor tanks and use gravity to fill. No transfer pumps needed, gravity always works on earth. Frees up deck space.

**4.0** Option available on DASH 4.0  
**2.0** Option available on DASH 2.0

## AUXILIARY CHEMICAL METER 4.0 2.0

Meter directly from barrels or totes. 5' or 6' high configurations.

## DECK BULKHEAD 4.0 2.0

No more tripping over hoses. Transition 3" hoses from above deck to below deck without restricting flow. Easy to orient hoses.

## MANIFOLD 4.0 2.0

Manage up to 3 tanks with a central fill/draw point. 3" ports configured for high flow. Fill with 3", 4" or 6" ports.

## BOOM KIT 4.0 2.0

No more lugging heavy hose. Mounts to Dash and has approximately 28' of total extension. Includes boom cradle and quick release handle. Premium hose Kit available.

## STEP KIT 4.0 2.0

Mounts under a step deck and makes getting on and off the deck safe and easy. Includes a grab handle.

## 13 HP HONDA WITH A 3" HYPRO PUMP 2.0

This motor has electric start and the pump is rated at 400gpm at 10psi.

## 6.5 HP HONDA WITH A 3" BANJO PUMP 2.0

This reliable pump is rated at 275gpm at 10psi.

## PUMP MOUNT KIT 2.0

Includes a universal mounting brackets for pump motors and poly fittings.

# SPECIFICATIONS



# DASH

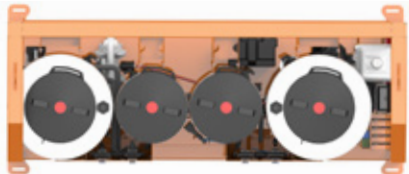

Dash 4.0



Dash 2.0 - Shown with  
Optional Pump



**Canada:**

108 New Hope Dr., Box 58  
Crystal City, MB R0K 0N0

**USA:**

68 Main Street, Box 54  
Sarles, ND 58372

**Toll Free:** 866.264.8030

**International:** 204.873.2448

[www.phiber.ca](http://www.phiber.ca)

This literature has been compiled for worldwide circulation. PhiBer reserves the right to change specifications, design and price of products described in this literature without notice. Please inquire to our sales network for any further information. Printed in Canada. Issued 1/2019

	DASH 2.0	DASH 4.0 Center Mount	DASH 4.0 Rear Mount
--	----------	--------------------------	------------------------

Size		DASH 2.0	DASH 4.0 Center Mount	DASH 4.0 Rear Mount
Width	in (cm)	65 (165)	102 (259)	102 (259)
Length	in (cm)	40 (102) *	36 (91)	36 (91)
Height	in (cm)	62 (158)	66 (169)	78 (198)
Weight	lb (kg)	440 (200)**	1400 (636)	1550 (704)

### Specifications

13 hp Honda w/ Hydro Pump	<input type="radio"/>	<input checked="" type="radio"/>	<input checked="" type="radio"/>
6.5 hp Honda w/Banjo Pump	<input type="radio"/>	<input checked="" type="radio"/>	<input checked="" type="radio"/>
30 gal (112 ltr) Inductor (Qty)	X 1	X 2	X 2
65 gal (245 ltr) Inductor (Qty)	X 1	X 2	X 2
Air Diaphragm Rinse Pump	24 GPM	40 GPM	40 GPM
Manual Hand Sprayer	<input checked="" type="radio"/>	<input checked="" type="radio"/>	<input checked="" type="radio"/>
Rear Tail Lights	<input checked="" type="radio"/>	<input checked="" type="radio"/>	<input checked="" type="radio"/>
Flip down rear work platform	<input checked="" type="radio"/>	<input checked="" type="radio"/>	<input checked="" type="radio"/>

### Options

Jug Knife Kit	<input type="radio"/>	<input type="radio"/>	<input type="radio"/>
Tote Platform	<input type="radio"/>	<input type="radio"/>	<input type="radio"/>
Work Platform	<input type="radio"/>	<input type="radio"/>	<input type="radio"/>
Cage with Tote Platform	<input type="radio"/>	<input type="radio"/>	<input type="radio"/>
Boom (25' total reach)	<input type="radio"/>	<input type="radio"/>	<input type="radio"/>
Premium Hose Kit for Boom	<input type="radio"/>	<input type="radio"/>	<input type="radio"/>
3 Tank Manifold	<input type="radio"/>	<input type="radio"/>	<input type="radio"/>
3" Deck Transition Bulkhead	<input type="radio"/>	<input type="radio"/>	<input type="radio"/>
3" Flow Meter	<input type="radio"/>	<input type="radio"/>	<input type="radio"/>
Light Kit (2 x LED)	<input type="radio"/>	<input type="radio"/>	<input type="radio"/>
Step Kit	<input type="radio"/>	<input type="radio"/>	<input type="radio"/>
Pump Mount Kit	<input type="radio"/>	<input type="radio"/>	<input type="radio"/>
Auxiliary Chemical Meter	<input type="radio"/>	<input type="radio"/>	<input type="radio"/>
Chemical Transfer Pump	<input type="radio"/>	<input type="radio"/>	<input type="radio"/>
3" Hose Reel	<input type="radio"/>	<input type="radio"/>	<input type="radio"/>
Tanks (3250/3750/4250 gallon)	<input type="radio"/>	<input type="radio"/>	<input type="radio"/>

Standard  Optional

### Requirements

3" Water Supply Line  
1" Water Supply Line (from Tank)

\* with pump it measures 49.5" (125cm)

\*\* with no pump



Complete trailer kits are available



INNOVATIVE DESIGN • PARTNERS IN EFFICIENCY