

DASH

by PHIBER

INNOVATIVE DESIGN • PARTNERS IN EFFICIENCY

PHIBER



Dash Concept

Brilliantly Fast

The design of the Dash has two primary objectives:

1. Keep the sprayer spraying by reducing fill times
2. Keep chemicals safely separated during sprayer loading

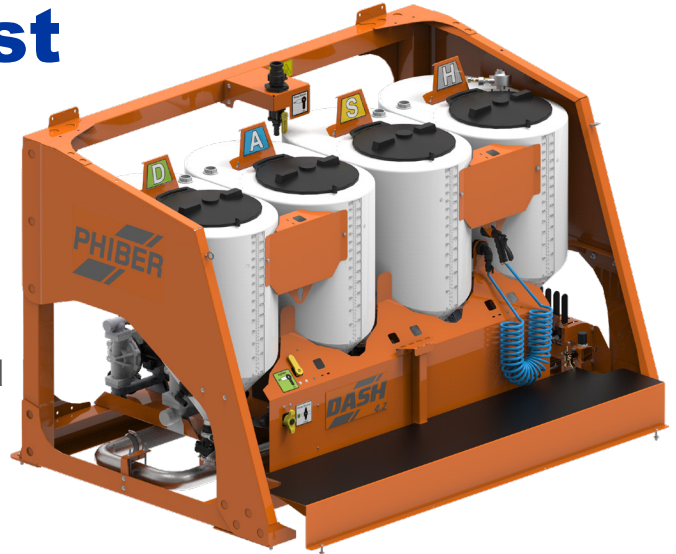

All inductors come with flip-up lids, and can be fitted with an optional jug knife.



Every inductor automatically rinses itself with every unload.

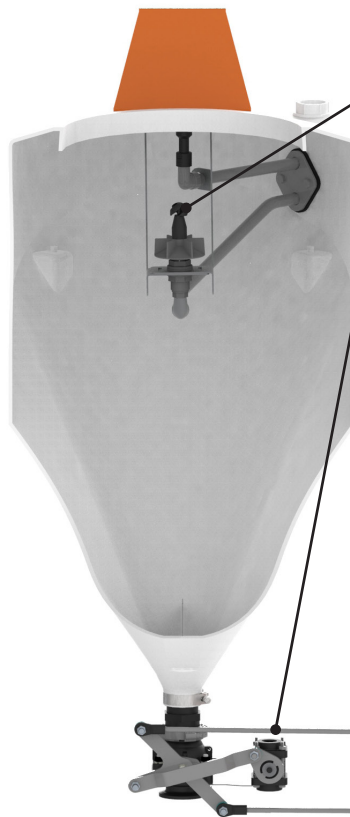

The Unique linkage shuts the rinse off before the main valve it closes, allowing for complete cleanout of each inductor.

The pull handles, located on the side of the Dash unit allow for the sprayer to be loaded completely from a single ground level station.

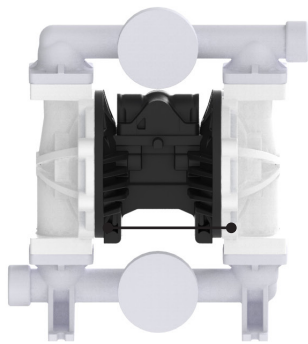

The Air-Powered Diaphragm Pump is the heart of the rinse and agitate system. This pump is used for rinsing jugs, inductors and getting dry chemicals into suspension. It also controls the hand sprayer, & wash down for a complete and easy cleanout .

Dash Concept



All Dash units include a QR Code that, when scanned, will take you to **PhiBer University**; watch videos on instaliation, training & best practices.

Choose a source for the rinse pump from either fresh water or draw from the very left inductor.

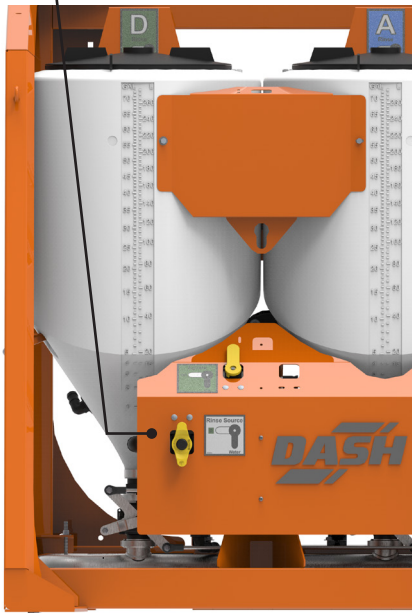

Inductor rinse system automatically turns on when chemical is being unloaded, washing and draining the inductor .

To rinse jugs, push to activate.

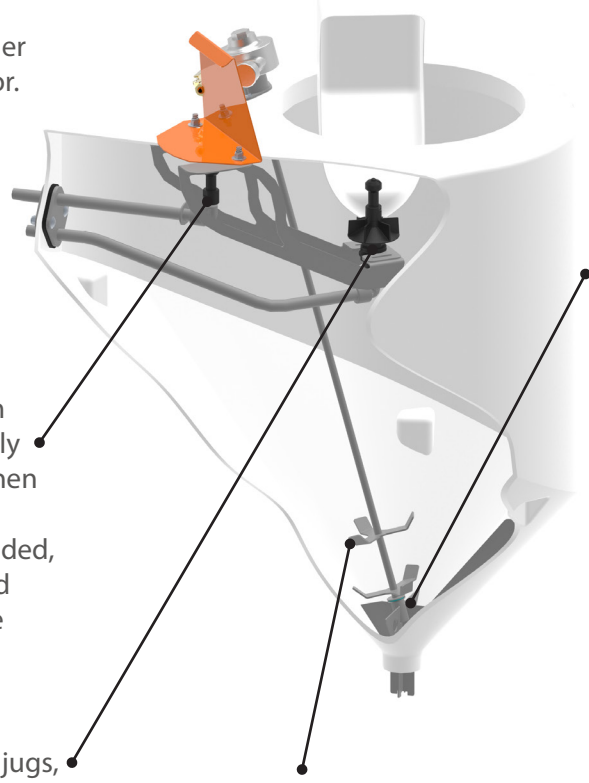

All inductors have anti-vortex plates which increase unloading speeds. It also reduces the amount of air being drawn into the water stream, minimizing foaming.

Each Dash comes standard with a water agitate in one inductor. An optional dry mix agitator (blender) is available to get heavier dry products into suspension.

Dash 2.0

Dash 2.0 has all the same features as its big brother, just in a smaller package.

Preload, Auto Rinse, Agitate Dry Products and Easy Cleanout are at the core of its design.

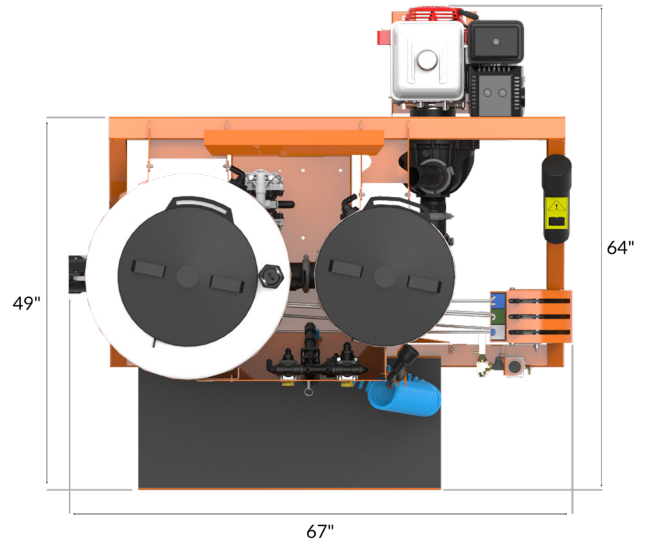

95 Gallons of Storage:

65 GAL Inductor x1
30 GAL Inductor x1

Easy to read indicators.

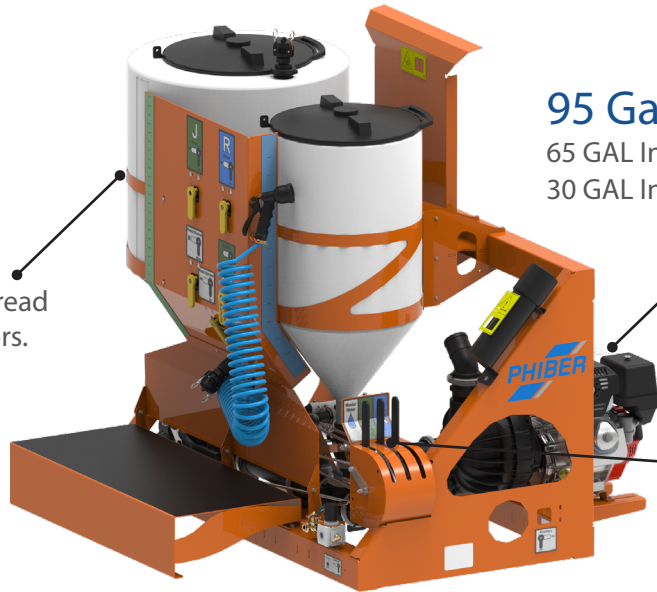

Shows with an optional 13HP Honda with hydro pump.

Handles allow for the operator to stand in one spot and unload inductors or meter from bulk containers.



INNOVATIVE DESIGN • PARTNERS IN EFFICIENCY

Dash 4.0 Rear



Designed to mount on the back of a tanker, flat deck trailer or grain box,

the Dash 4.0 Rear Mount has all the same features of the center mount Dash but with a different frame to support a different mounting. This model includes tail/turn lights, flip down work platform and a license plate holder.

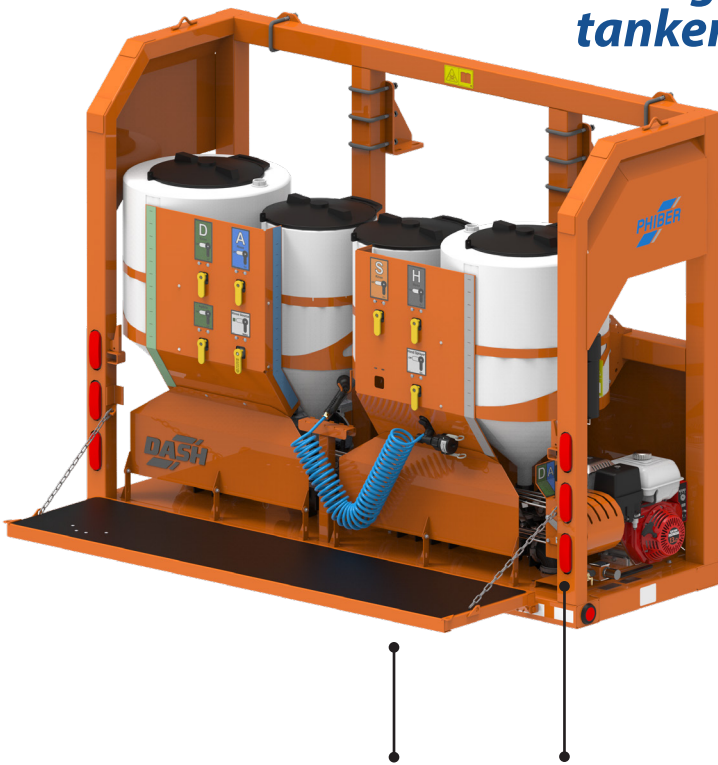

Rear mount includes tail lights and flip down deck.



Dash 4.2

Dash 4.2 is designed to maximize efficiency, increase chemical efficacy

Four 75 gal (285 ltr) inductors for 300 gal (1,140 ltr) of total chemical storage give lots of capacity for large mixes.

Easy to ready indicators.



Comes standard with a 13HP Honda, electric start motor and 3" hypro pump.

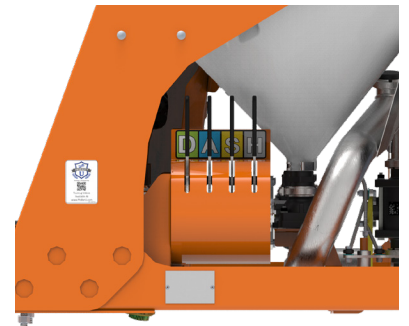
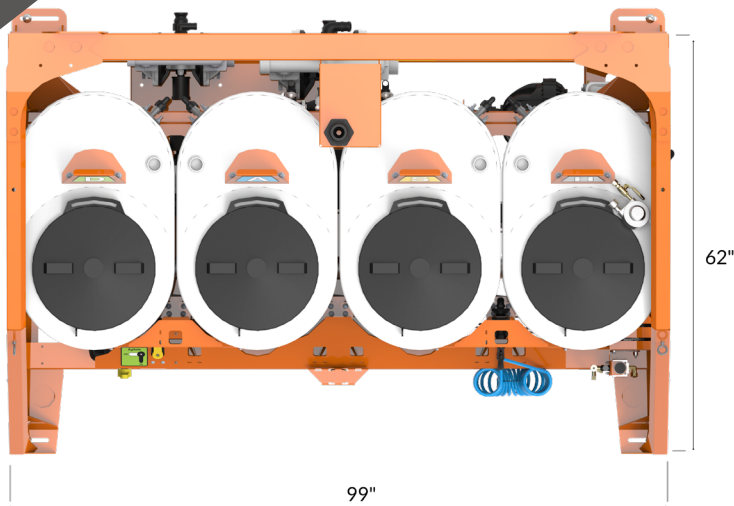

Easy to pull handles allow the operator to stand in one spot and unload inductors.

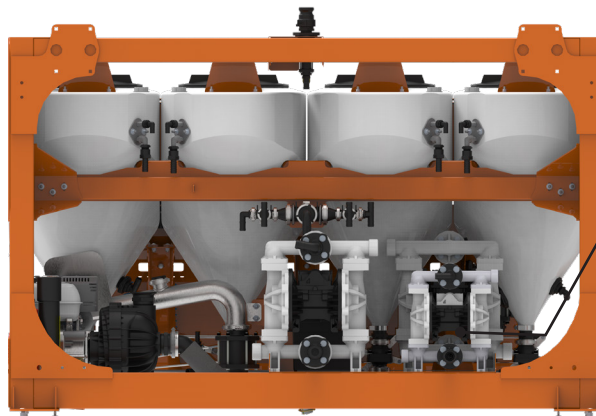

Up to two optional chemical transfer pumps are available.



INNOVATIVE DESIGN • PARTNERS IN EFFICIENCY

Dash 4.2



Dash Options

4.2 Option available on DASH 4.2

2.0 Option available on DASH 2.0



TANKS 4.2 2.0

Includes hoops for mounting & internal baffles.

Capacity (Gal)	(W" x L" x H")
3250	88 x 146 x 79
3750	88 x 146 x 91
4250	88 x 146 x 101



TOTE HOSE
4.2 2.0



RATCHET STRAPS
4.0 2.0



4 WHEEL RAMP KIT 4.2

WORKING PLATFORM

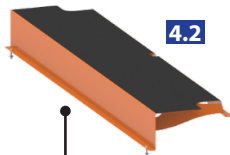

4.2



JUG KNIFE KIT 4.2 2.0



DRY AGITATOR KIT 4.2 2.0



3" HOSE REEL



REAR OR SIDE REFILL



CAGE WITH TOTE PLATFORM 4.2 2.0

STEP KIT 4.2 2.0



MANIFOLD 4.2 2.0



INNOVATIVE DESIGN • PARTNERS IN EFFICIENCY

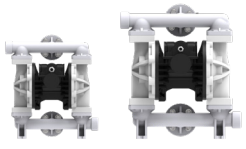

**CHEMICAL
TRANSFER PUMP**
4.2 2.0
Choose from a 20
GPM or 40 GPM
pump



DUAL BOOM KIT 4.2 2.0

LIGHT KIT 4.2

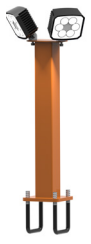

TOTE PLATFORM 4.2



TOTE RINSE KIT 4.2



AUXILIARY CHEMICAL METER 4.2 2.0



Dash Options



DECK BULKHEAD 4.2 2.0



BOOM KIT 4.2 2.0



60 GAL AIR STORAGE KIT 4.2 2.0



CARGO NET 4.2 2.0

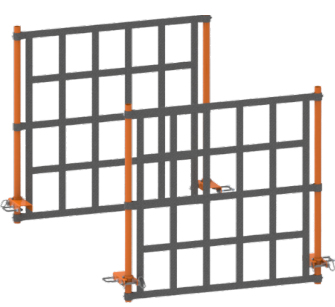

BOOM BLOWOUT 4.2 2.0



LADDER KIT 4.2



TRAILER LIGHTING KIT 4.2 2.0



Trailer Packages

Pintle Trailer

- Spring Ride Suspension
- 3,250 gal Water Capacity
- Four Tote Capacity
- Two Dash Options
- Dash 2.2 or 4.2 Available



28' Goose Neck

- Spring Ride Suspension
- 3,250 gal Water Capacity
- Four Tote Capacity
- Dash 2.2 or 4.2 Available



45 ft Tandem

- Air or Spring Ride Trailer Option
- Multiple Water Capacity Options Up To 6,500
- Eight Tote Capacity
- Dash 4.2 Standard



INNOVATIVE DESIGN • PARTNERS IN EFFICIENCY

Sprayer Trailer

- Air Ride Suspension
- Multiple Water Capacity Options Up To 3,750 gal
- 4 Tote or Pallet Carrying Capacity
- Dash 4.2 Standard



45ft. Tri-Axle

- Air Ride Suspension
- Multiple Water Capacity Options Up To 8,000 gal
- 8 Tote or Pallet Carrying Capacity
- Dash 4.2 Standard



50ft. Tri-Axle

- Air Ride Suspension
- Multiple Water Capacity Options Up To 8,000 gal
- 12 Tote or Pallet Carrying Capacity
- Dash 4.2 Standard

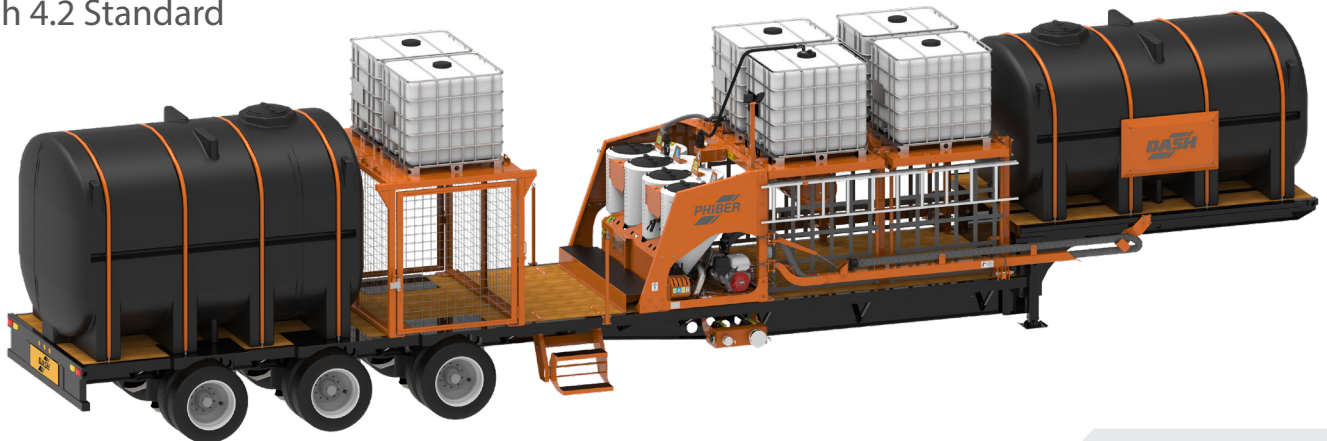

Specifications



		Dash 2.0	Dash 4.0 Rear	Dash 4.2 Center
Size				
Width	in (cm)	65 (165)	102 (259)	99 (251)
Length	in (cm)	40 (102)*	36 (91)	62 (157)
Height	in (cm)	62 (158)	78 (198)	62 (157)
Weight	in (cm)	440 (200)**	1550 (704)	1400 (636)

Dash Specifications

13 hp Honda w/ Hydro Pump	○	●	●
6.5 hp Honday w/ Banjo Pump	○		
75 gal (284 ltr) Inductor (Qty)	X 2	X 4	X 4
Air Diaphragm Rinse Pump	20 GPM	40 GPM	40 GPM
Manual Hand Sprayer	●	●	●
Rear Tail Lights		●	
Flip Down Rear Work Platform		●	

Requirements

3" Water Supply Line

1.5" Water Supply Line

3/8" Air Supply

* with pump it measures 49.5" (125cm)

** with no pump

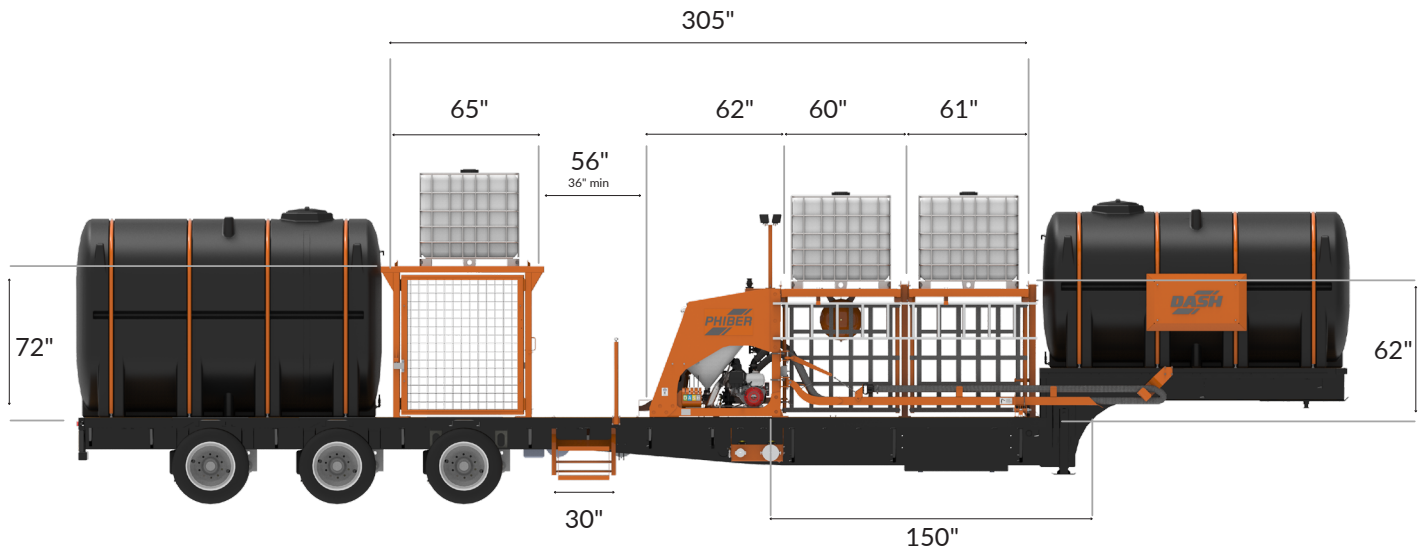

CANADA

108 New Hope Dr., Box 58
Crystal City, MB R0K 0N0

USA:

68 Main Steet, Box 54
Sarles, ND 58372

Toll Free: 866.264.8030

International: 204.873.2448
www.phiber.ca



INNOVATIVE DESIGN • PARTNERS IN EFFICIENCY